



DSM Press-In Technique  
*Silver-Line*

## Technical Specification

### Attention !

Before putting into operation, please observe hint on page 35!

Serial No.	Commission

 English

**DSM**<sup>®</sup>  
DSM Messtechnik GmbH

**TEMP**

## PROOF OF VERSION

Version	Date	Remark
A	25.09.2001	In course of the reform of the documentation, a new document no. has been assigned (old: 864 6 07 13 Date: 03/2001).
B	06.11.2001	2 new pages 'Certificate', replace previous press specification. Paging and index revised.
C	05.12.2001	Page 26 changed, 24 V supply voltage LED added.
D	27.06.2002	Page 30 and 31 'Disconnection Press Motor' changed.
E	09.09.2002	Technical datas, page 12 and 13 as well as the dimension drawings revised respectively supplemented.
F	05.06.2003	Technical datas, page 12 and 13 corrected.
G	29.01.2004	Declaration of conformity / manufacturers declaration revised.
H	15.07.2004	Dimensions of the precision presses corrected.
I	15.03.2005	Divers corrections.
J	14.07.2005	Divers corrections.

## IMPRINT

### Publisher

DSM Messtechnik GmbH Register Court  
AA, No. B 431-A | Place of business:  
Aalen, Germany | Managing Director: Mr.  
Raimund Wilhelm | VAT No.: DE  
144633038

### Documentation

Operating Manual EMP Doc.  
No. BA0064-e-9607-J Date:  
14.07.2005

### Address

DSM Messtechnik GmbH  
Dieselstraße 16 D-73431 Aalen

### Contact

Tel.: +49 (0) 7361 / 5717 - 0  
Telefax +49 (0) 7361 / 5717- 33  
www.dsm-messtechnik.de  
info@dsm-messtechnik.de

### Hint

Technical modifications reserved!  
Modifications which help the  
progress are possible at any time  
without advance notice from DSM  
Messtechnik GmbH, Germany.

Texts, graphics and pictures of  
this manual are subject to the  
protection of the copyright and of  
the laws for protection of  
intellectual property.

## PREAMBLE

### Dear Customer,

we're glad that you've chosen a precision press of DSM. Please observe our assembly and operating instructions. By that you save time and avoid at best possible mistakes. Additional technical datas you find in the operating manuals of the system components. In case of doubts or by complaints, our employees will be glad to help you at any time. Just contact them by phone.

If you observe our manuals and hints, this DSM

product will completely meet your expectations.

With the best regards,  
Your DSM-Team

Managing Director: Mr. Raimund Wilhelm  
Register Court Aalen, Germany: No. B 431-A

Place Of Business: Aalen, Germany

## INDEX

Important hint .....	Page 04	Mechanical installation .....	Page 26
Type plate .....	Page 04	Lubrication diagram .....	Page 27
Safety labelings .....	Page 05	Data sheet of the lubricant .....	Page 28
Survey DSM - complete system EMP ...	Page 06	Lubrication set .....	Page 29
Technical datas 'Load Cell' .....	Page 07	Function description measuring and control electronics .....	Page 30
Technical datas 'Precision Press' .....	Page 08	Electrical installation .....	Page 32
Function description press .....	Page 09	Configurations X81 BRUSI; X80 Force/Length; X81 Trigger..	Page 33
Replacement components .....	Page 10	Switch-Off Example Disconnection motor EMP 3xx and 4xx ..	Page 34
Assembly instruction Description replace motor, load cell and guide .....	Page 12	Disconnection motor EMP 5xx .....	Page 35
Assembly sketch .....	Page 13	DSM certificate .....	Page 36
Exchange circuit board .....	Page 14	Contacts / location plan .....	Page 37
Dimension drawings EMP 3002, 3005, 301 .....	Page 15	DSM service form .....	Page 38
EMP 302 .....	Page 16	EG declaration of conformity EG manufacturers declaration .....	Page 39
EMP 405, 410 .....	Page 17		
EMP 405, 410 with motor offset (V2) .....	Page 18		
EMP 520 .....	Page 19		
EMP 520 with motor offset (V2) .....	Page 20		
EMP 530, 550 .....	Page 21		
EMP 530, 550 with motor offset (V2) .....	Page 22		
EMP 530, 550 with 300 mm stroke .....	Page 23		
EMP 570 .....	Page 24		
Notes .....	Page 25		

## ATTENTION, IMPORTANT HINT !

The component Electro Mechanical Precision Press, delivered by DSM, will only be a system after installation into a plant with a corresponding protection device.

A professional installation of the components is necessary to protect the precision press of mechanical damages.

In precision press EMP, the functional part 'BRUSI' protects this of a mechanical damage.

How this functional part works, you can get from this operating manual (→ see chapter 'Measure and Control Electronics').

**ATTENTION!** The electrical operated units you run from DSM Messtechnik GmbH may only be disconnected from the power line in case of emergency or after closing hour. The cyclic switch-off of the mains voltage is forbidden (e.g. for completion of a safety function).

## TYPE PLATE

<b>DSM</b> Dieselstraße 16, D-73431 Aalen	
1 TYPE: EMP520	2 S.-Nr.: 48   5127
3 F.-Kalibrierwert	20000 N
4 F.-Faktor (Kraft)	1
5 S.-Faktor (Weg)	144
6 Motor invers	1
7 Weg invers	0
8 Weg x4	1
9 maximaler Hub	160 mm
10 Platine: S.-Nr.:	EMP 1.1 -
11 Motor: S.-Nr.:	BLP28120-RL1 9054112
12 Druckdose: S.-Nr.:	K13 20kN 39922

**Hint:** The values, entered in the shown type plate are only examples !

- 6 Direction of rotation of the motor  
INVERS = 0 Direction of rotation as specified in the press-in diagram  
INVERS = 1 Direction of rotation is reversed
- 7 Direction of rotation of the angle impulse  
INVERS = 0 Direction of rotation as specified  
INVERS = 1 Direction of rotation is reversed
- 8 Depending on the type of motor, it may be necessary, to multiply the amount of the impulses with 4 to get the correct result.
- 9 Max. stroke of the press mm
- 10 Serial and version number of the control electronics
- 11 Type description and serial number of the motor
- 12 Type description and serial number of the load cell as well as the specification of the max. force

- 1 Type description of the precision press
- 2 Serial number of the precision press
- 3 Max. press-in force of the press in Newton
- 4 Correction factor for the force measurement
- 5 Length factor which specifies, how many impulses the position encoder has to deliver per mm

### HINT!

The values, entered on the type plate of the DSM precision press, have to be entered in the menu 'Constants' in the control unit (Multisystem FL-A, Multisystem FL-G-A).

## SAFETY LABELINGS



### HINT!

To protect you from electric shock, risk of accident and fire danger, the following fundamental safeguards have to be observed at any time, if using power tools. Read and observe these hints before you use the unit. Keep this specification (safety labelings) in a safe place!

**Keep your operating range tidy .** Disarrangement in the operating range causes risk of accident.

**Consider environmental influences.** Don't use the electric units in wet or damp environments. Take care of good illumination. Don't use the electric units near flammable liquids or gases.

**Protect yourself from electric shock.** Avoid physical contact with solidly grounded parts like e.g. pipes, radiators or other connected electrical machines.

**Don't overload your units.** You work better and more safe in the specified range of performance. Make sure, that always the calibration value, listed on the type plate of the press, is adjusted in the control unit.

**Use the correct tool.** Don't use any inefficient presses or additional parts for press-in processes for which these aren't designed. Don't use presses for functions or operations for which the aren't defined.

**Wear adequate working clothes.** Don't wear any roomy clothes or jewelry. You may be gripped by moving parts. Wear a hairnet by long hair.

**Maintain your tools with care.** Check the cable regularly and let it be replaced by a specialist in case of damage. Check extension cables regularly and replace them if damaged. Keep handles dry and free from oil and fat.

**Avoid unintended switch-on.** Make sure, that the switch isn't on by connection to the mains supply.

**Check your tool for damages.** Before further use of the units you have to check the protective devices or other parts accurately for their efficient and intended function. Check, if the function of moving parts is ok, if they can be moved, if no parts are broken, if all other parts are efficient, correct assembled and all other conditions which may have influence in the operation of the unit are correct. Damaged protective devices and parts shall be repaired or replaced appropriate by a service technician of DSM. This, as far as nothing else is mentioned in the manuals. Damaged switches or plugs have to be replaced at DSM. Don't use any units at which the switch or any plugs are defect.

**Attention.** For your own safety only use accessories and accessory units which are specified in the manual or which are quoted in the respective product specifications. The use of other units as recommended in the manual or in the catalogue isn't allowed.

**Repair only by DSM.** The electric units refer to the corresponding safety regulations. Repairs may only be carried out from a DSM specialist. Otherwise accidents for the operator may happen for which DSM is not responsible.

**Vibration-free setting up.** It's absolute necessary to run the electronics at a vibration-free location.

**Environmental temperature.** The environmental temperature is not allowed to be more than 40°C. In case of transgression it has to be cared of adequate cooling.

# SURVEY

## DSM Complete System EMP

The electro mechanical precision press is a component of the DSM complete system 'Press-In Technique'. The system consists of the fundamental components press-in control unit (Multisystem FL-A, FL-G-A), power pack (Multisystem BL-L or BL-H) and of the electro mechanical precision press (EMP ...) as well as of the interconnecting cables (standard = 5 m, also deliverable: 10 m, 15 m).

A programmable from memory control unit isn't necessary for operation. But, this can be connected with the control units Multisystem FL-A respectively FL-G-A at any time. To that, the control unit FL-G-A optionally can be extended with a profibus interface or with an ethernet (TCP/IP) interface.

**A protective circuit respectively an emergency stop device isn't part of this complete system. The operator himself has to take care of a protection device.**

**However, DSM won't take over any liability for perhaps damages or their consequences.**

As standard the control unit contains a statistics (up to 32000 values per program) as well as a histogram of the press-in stroke and a histogram of the press-in force.

This data as well as constants, parameters and programs (+ programming commands) can be printed with a printer of type Multisystem PR-I.

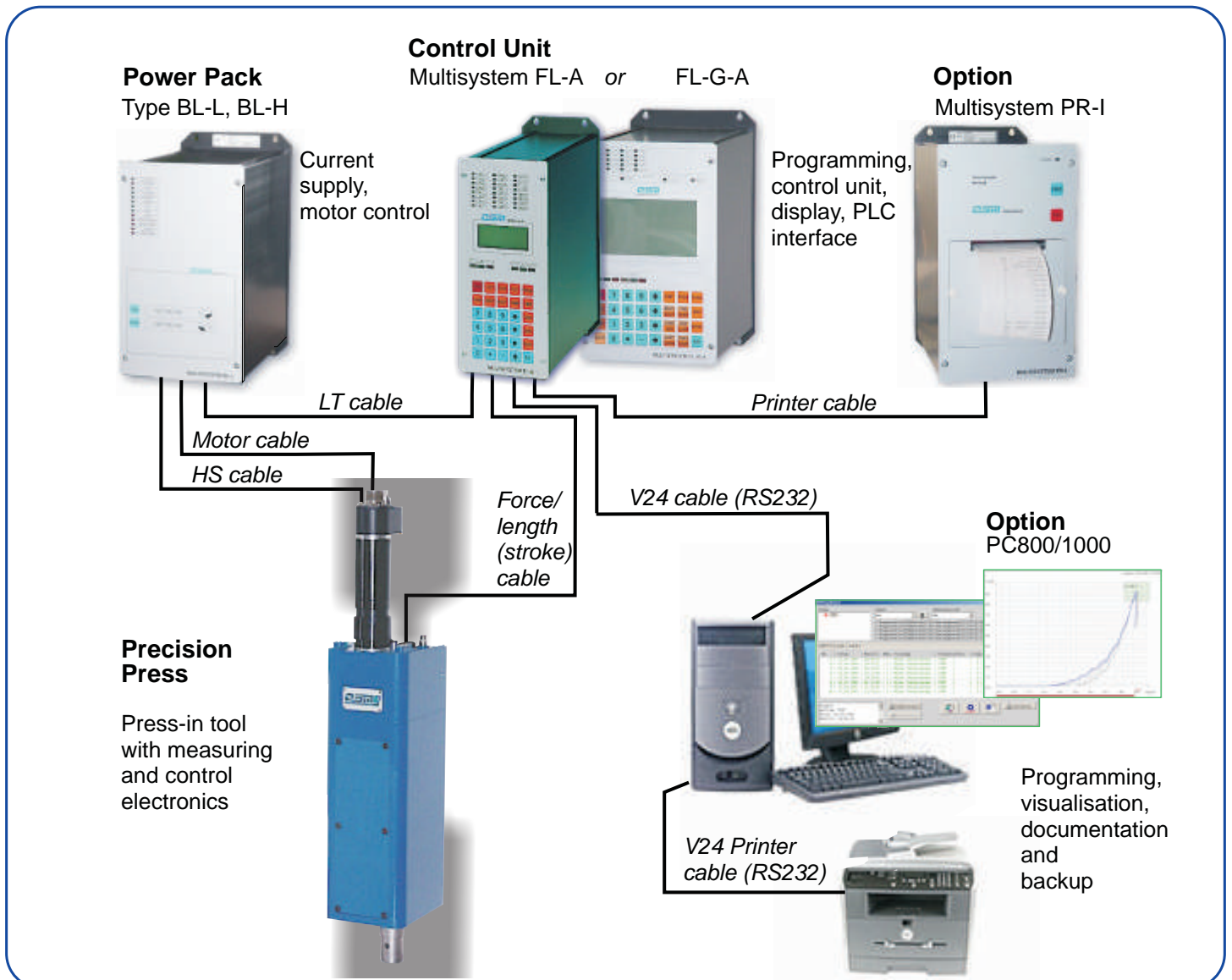

# TECHNICAL DATAS

## Load Cell

Measuring range	kN	1/2/5/10/20/50/70
Accuracy class	S%	0,5
Working load	S%	130
Maximum load	S%	150
Breaking load	S%	> 300
Max. dynam. load (DIN 50100)	S%	70
Nominal measurement range	mm	< 0,3
Jumper resistance		350
Insulating resistance		$>2 \cdot 10^9$
Supply voltage	V	2 ... 12
Max. supply voltage	V	15
Nominal characteristic value (S)	mV / V	1,0
Temperature coefficient of the nominal characteristic value	S% / 10K	0,2
Temperature coefficient of the neutral signal	S% / 10K	0,2
Reference temperature	°C	23
Nominal temperature range	°C	-10 ... +50
Operating temperature range	°C	-30 ... +80
Storage temperature range	°C	-50 ... +95
Compound failure	S%	0,25
Creeping failure	S% / 30 min	$< \pm 0,1$
Protection category	IP 65	
Material	Rust-resistant high quality steel	

in kN	A	B	C	D	H
1 / 2 / 5 / 10	32	8	10	1,8	20
20	39	11	16	2	24
50	52	15	25	3	40
100	79	20	39	5	50

Dimensions in mm

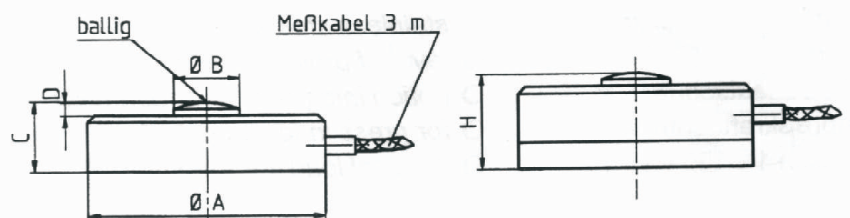

# TECHNICAL DATAS

## Electro Mechanical Precision Press

	EMP 301	EMP 302	EMP 403	EMP 405	EMP 410	EMP 510	EMP 520	EMP 525	EMP 530	EMP 550	EMP 570
Nominal force [kN]	1	2	3	5	10	10	20	25	30	50	70
Stroke 100 mm	●	●	●	●	●						
Stroke 160 mm	—	—	—	—	—	●	●	●	●	●	●
Stroke 250 mm	—	—	○	○	○	—	—	—	—	—	—
Stroke 300 mm	—	—	—	—	—	○	○	○	○	○	○
Stroke 500 mm	—	—	—	—	—	○	○	○	○	○	○
Speed [mm/s] <sup>1</sup>	128	128	115	115	115	90	90	180	90	90	90
Length/stroke x4 (1)	—	—	—	—	—	●	●	●	●	●	●
Length/stroke repeat accuracy (<math>\pm 0,02\text{ mm}</math>) <sup>2</sup>	●	●	●	●	●	●	●	●	●	●	●
Resolution length/stroke measurement (0,003 mm)	●	●	●	●	●	●	●	●	●	●	●
Accuracy force measurement (1% of the final value)	●	●	●	●	●	●	●	●	●	●	●
Tool fitting DIN810 [Ø mm]	16	16	25	25	25	25	25	25	25	25	25
Weight of the press [kg]	10	10	15	15	15	75	75	75	75	75	75

The precision press will keep the specified exactitudes. If the tool has a spring back characteristic, this will affect contrary to the reached accuracy.

<sup>1</sup> in both directions continuous selectable <sup>2</sup> by 30% of the max. speed and no-load stroke ex reference point

### HINT!

By horizontal assembly  $\pm 0,3$  mm axial deviation of specified weight of tool.

### Assembly and Maintenance References

Basically the precision press EMP has to be built in, so that the influence of transverse forces is as little as possible. By higher forces and a long distance of the point of pressing to the EMP, this is achieved by an additional guide. If the press is permanent loaded with high transverse forces, this will result in a reduction of the durability of the press.

Possibly a separate guide for support of the weights has to be planed by the customer, if the press is mounted horizontal. This depending on the execution of the pressing tool.

The precision press isn't completely maintenance-free. We recommend to lubricate the recirculating ballscrew as well as the helical gear box within a raster of 500 000 pressings. Procedure as described on page 273.

If problems at the press-in system arise, please also observe the text indicator of the control unit. If a repair of the precision press EMP becomes necessary, please only send this after previous date arrangement with our service department (Tel.: +49 (0) 7361 / 5717 - 27).

## FUNCTION DESCRIPTION

### Electro Mechanical Precision Press

The brushless motor runs the spindle of the precision press. The rotation of the motor is transferred onto the linear axis by a helical gear box.

Different tools can be mounted into the tool fitting (acc. to DIN 810) at the plunger.

→ See drawings on the pages 15 up to 24.

There's a load cell in the electro mechanical precision press which converts the measured force into a measurement signal. The movement of the plunger (↑ up and ↓ down) is controlled by the DSM length/stroke sensoric.

The force measurement signal is amplified in a electronic measuring equipment. Both signals (force and length/stroke) are pooled in a measuring transformer and from there send to the control unit.

4 hallsensors and 2 break fuses are built-in in the precision press (measuring and control electronics). The four hallsensors are connected with the control unit and are interrogated from there.

The four hallsensors once have the function of stroke limitation of the built in spindle. An other function is the reference point (length/stroke

zero point).

→ See 'Measuring and Control Electronics' (page 30)

The switch off of the press by normal operation:

The movement of the motor is defined stopped, if one of the stop criterions (e.g. force, length/stroke, time), which is specified in the program, is fulfilled. The reference values of the precision press are compared with the switch off specifications in the control unit.

The evaluation is shwon as follows:

- ❶ as plain text in the display
- ❷ via LED at the unit
- ❸ via external outputs (e.g. directly via indicator lamps)

Code type description of the precision press:

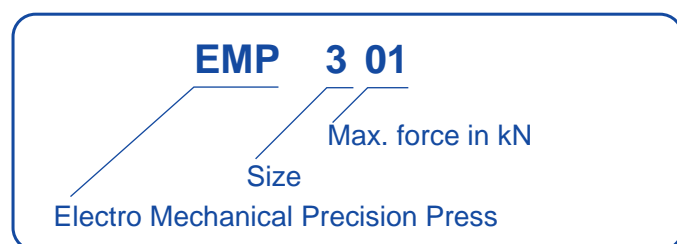

## REPLACEMENT COMPONENTS

If defect or worn out, the following listed components can be replaced by the customer himself. For this, please observe to specify the respective article number in case of ordering replacement components (observe type description of the precision press). If changing components, please proceed according to the assembly instructions.

In case of other damages (defects) at the precision press, you should contact our service department (Tel. +49 (0) 7361 / 5717 - 27).

### Motor, Motor Offset, Guide Plunger

#### Component: Motor



Description	Article Number
Motor EMP 301 (complete set)	DSM 280605
Motor EMP 302 (complete set)	DSM 280655
Motor EMP 4xx (complete set)	DSM 280705
Motor EMP 520 (complete set)	DSM 280805
Motor EMP 530/550/570 (complete set)	DSM 280855

#### Component: Offset (without motor)



Description	Article Number
Offset for motor EMP 3xx (without motor)	DSM 280654
Offset for motor EMP 4xx (without motor)	DSM 280704
Offset for Motor EMP 5xx (without motor)	DSM 280854

#### Component: Guide Plunger



Description	Article Number
Guide Size 3 (EMP 3xx)	DSM 280 608
Guide Size 4 (EMP 4xx)	DSM 280 708
Guide Size 5 (EMP 5xx)	DSM 280 808

# REPLACEMENT COMPONENTS

## Load Cell, Electronics

### Component: Load Cell



<i>Description</i>	<i>Article Number</i>
Load Cell 1 kN (EMP 301)	DSM 280300
Load Cell 2 kN (EMP 302)	DSM 280305
Load Cell 5 kN (EMP 405)	DSM 280310
Load Cell 10 kN (EMP 410)	DSM 280315
Load Cell 20 kN (EMP 520)	DSM 280320
Load Cell 50 kN (EMP 550)	DSM 280325
Load Cell 70 kN (EMP 570)	DSM 280331

### Component: Measuring and control electronics



<i>Description</i>	<i>Article Number</i>
Circuit Board EMP 1.2 100 (for sizes 3, 4)	DSM 280623
Circuit Board EMP 1.2 160 (for sizes 5, 6)	DSM 280809
Break Fuse (1set, for all sizes)	DSM 280611

# ASSEMBLY INSTRUCTION

## Descriptions

### Replace motor !

Unscrew the coupling nut ❶\* from the motor with a open-ended wrench size 50.  
Attention: The coupling nut has a left-hand thread (LH)!!!

Change the motor adapter from the defect onto the new motor.  
Screw on the new motor.

### Replace load cell !

Unscrew the screws \* of the cover. If all screws are unfastened, take off the cap.

*A) by the presses of type EMP 3xx and 4xx*

Unscrew the cap of the case \*. Disconnect the plug of the load cell careful from the circuit board (*description circuit board page 14*).

*B) by the presses of type EMP 5xx*

Disconnet the plug coupler which is direct at the load cell.

Take out the load cell \* out of the case and insert the new load cell (pay attention to the position !!!). Close case again.

### Replace guide plunger !

Unscrew the screws of the guide ❷\* and remove this by pulling it over the plunger ❸\*.  
Insert new guide and tighten it.

**ATTENTION!** By all workings at the precision press it has to be assured, that the equipment is switched electroless and protected against re-start.

**HINT!** \*) The numbers like e.g. ❷ are hints for the assembly sketch on page 13 !

# ASSEMBLY INSTRUCTION

## Assembly Sketch

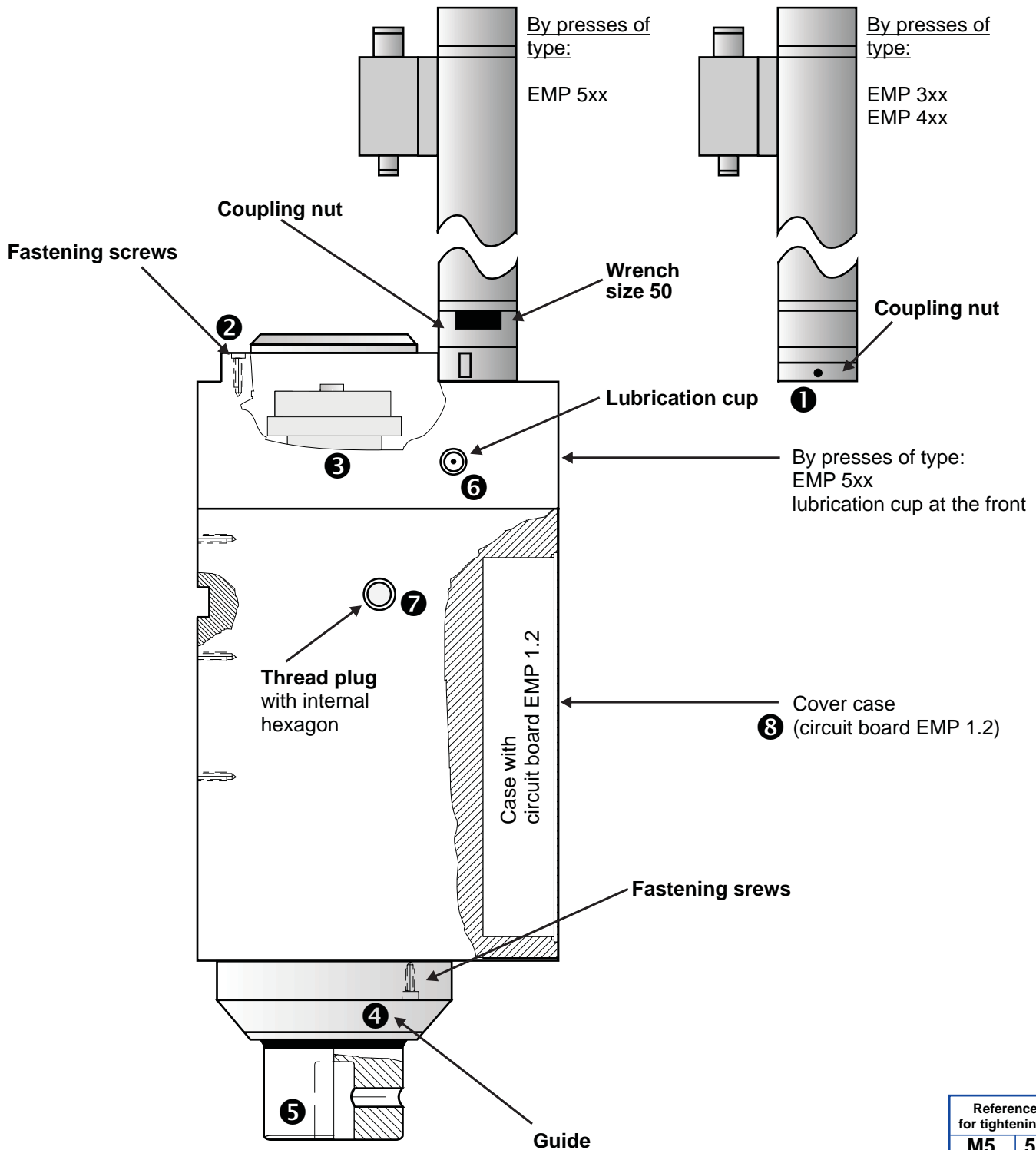

Reference values for tightening torques	
M5	5,5 Nm
M6	9,5 Nm
M8	23 Nm
M10	46 Nm
M12	79 Nm

Side view from left

# ASSEMBLY INSTRUCTION

## Replace circuit board

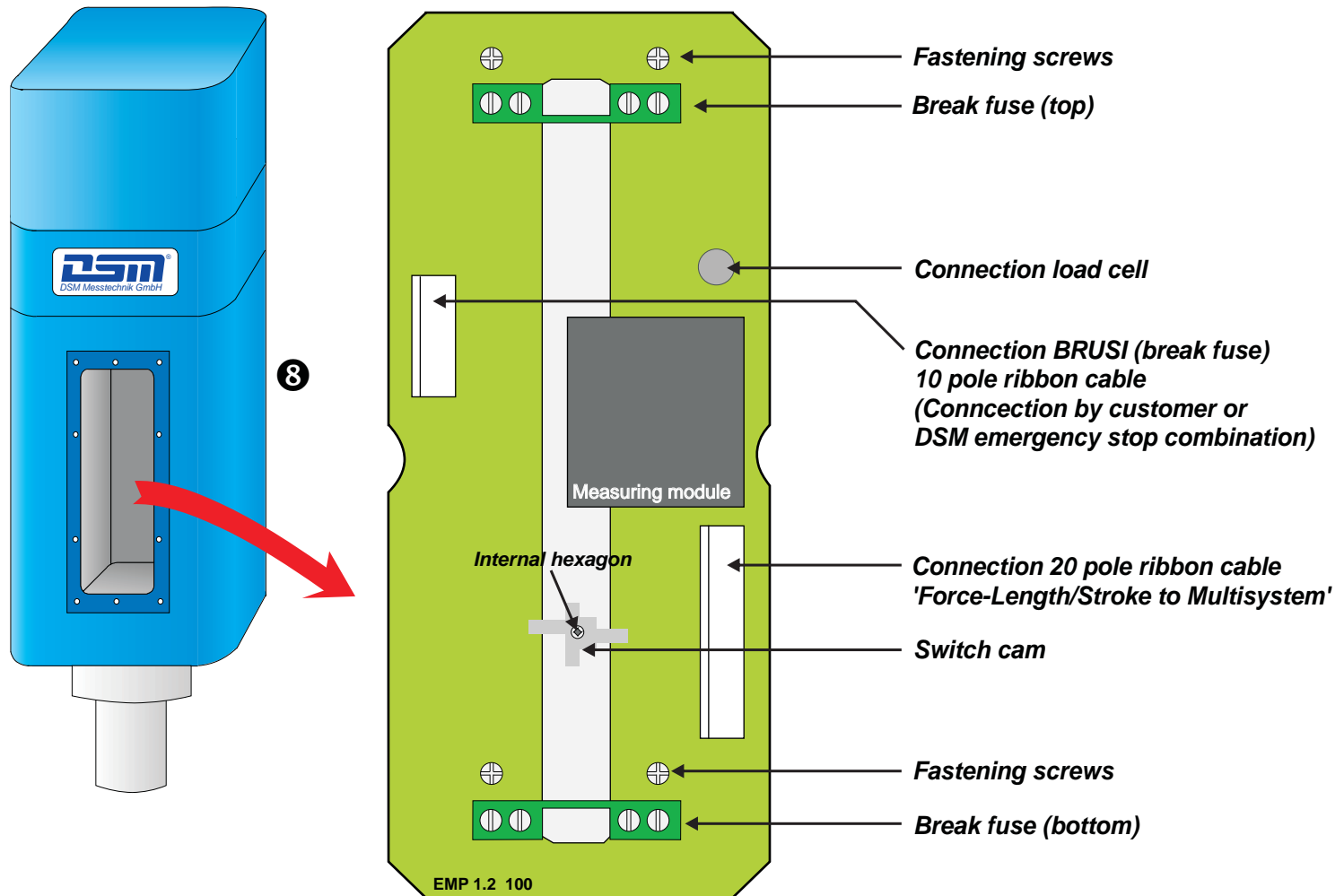

1. Switch equipment electroless. Only then unscrew the screws at the cover of the case. You see the circuit board EMP 1.2 after the cover of the case is removed. Before this can be removed, all cable connections (force transducer cable, 10 pole ribbon cable, 20 pole ribbon cable) have to be disconnected. Following that, unscrew the fastening screw of the switch cam by using a hexagon socket wrench. As soon as you've dismantled the switch cam, you can unscrew the fastening screws of the EMP 1.2 circuit board. Now take out the circuit board out of the case and replace this by a new EMP 1.2 circuit board. The assembly is made in reversed order.

### HINT!

To exchange a break fuse you only have to unscrew the 4 screws at the defect break fuse and replace the damaged one by a new break fuse.

# DIMENSION DRAWING

## EMP 3002, EMP 3005, EMP 301

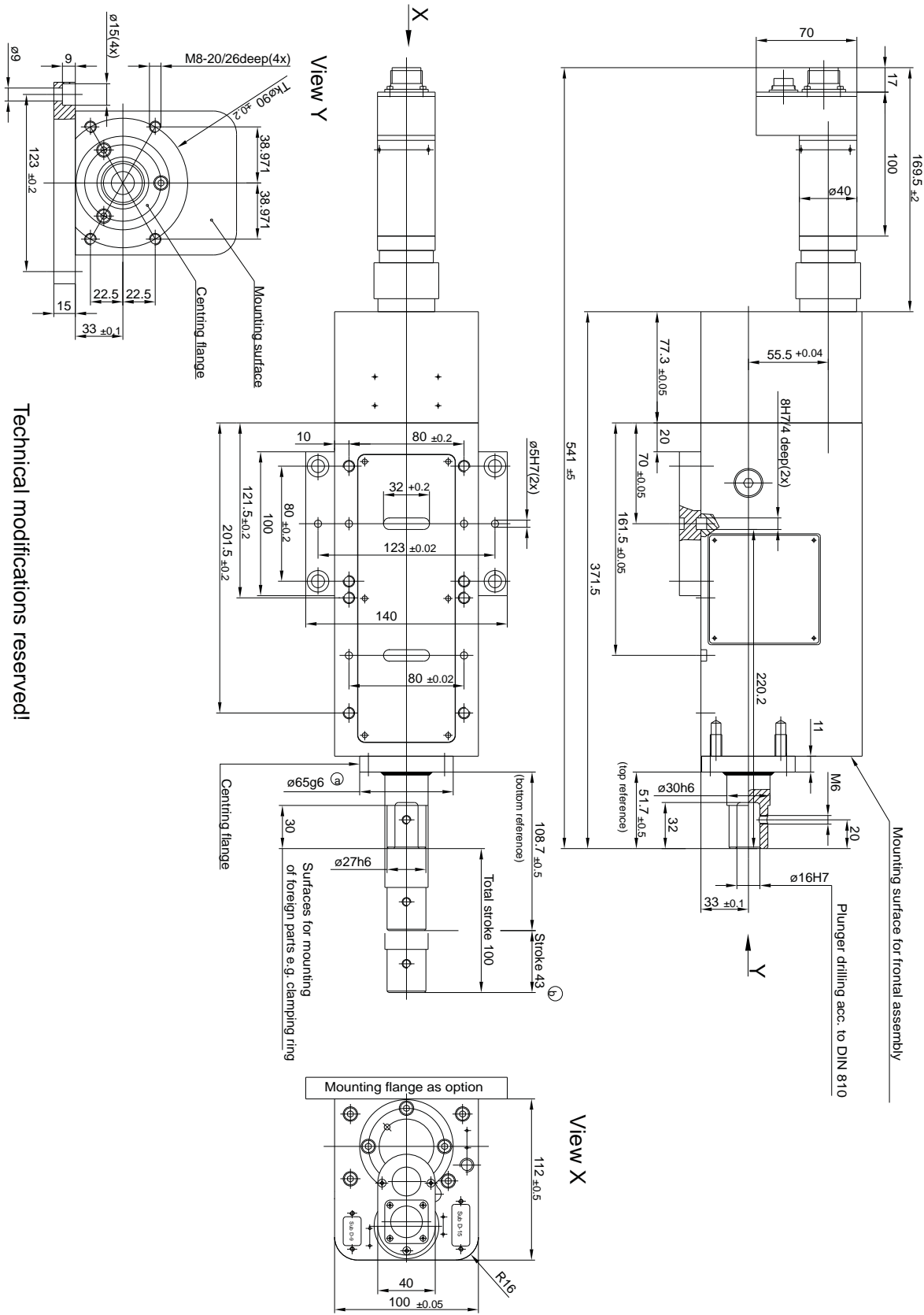

Technical modifications reserved!





# DIMENSION DRAWING

## EMP 405, EMP 410 with Motor Offset (V2)

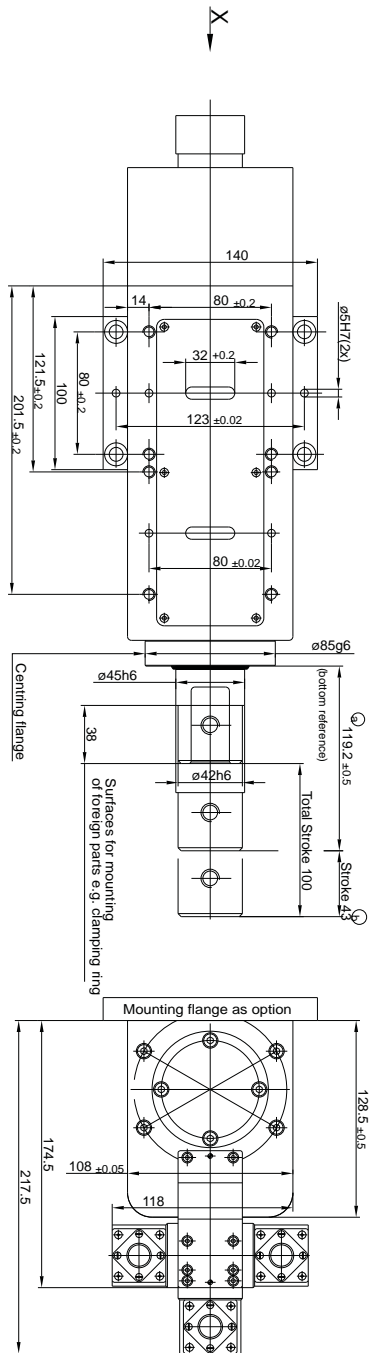
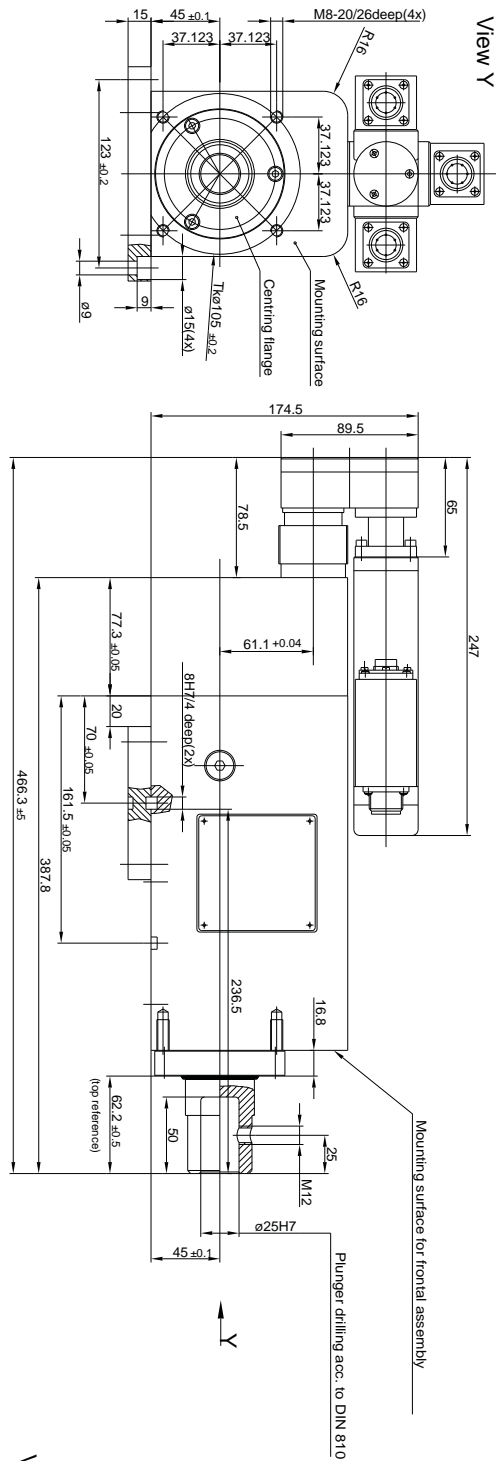

Technical modifications reserved!



# DIMENSION DRAWING

## EMP 520 with Motor Offset (V2)

Technical modifications reserved!

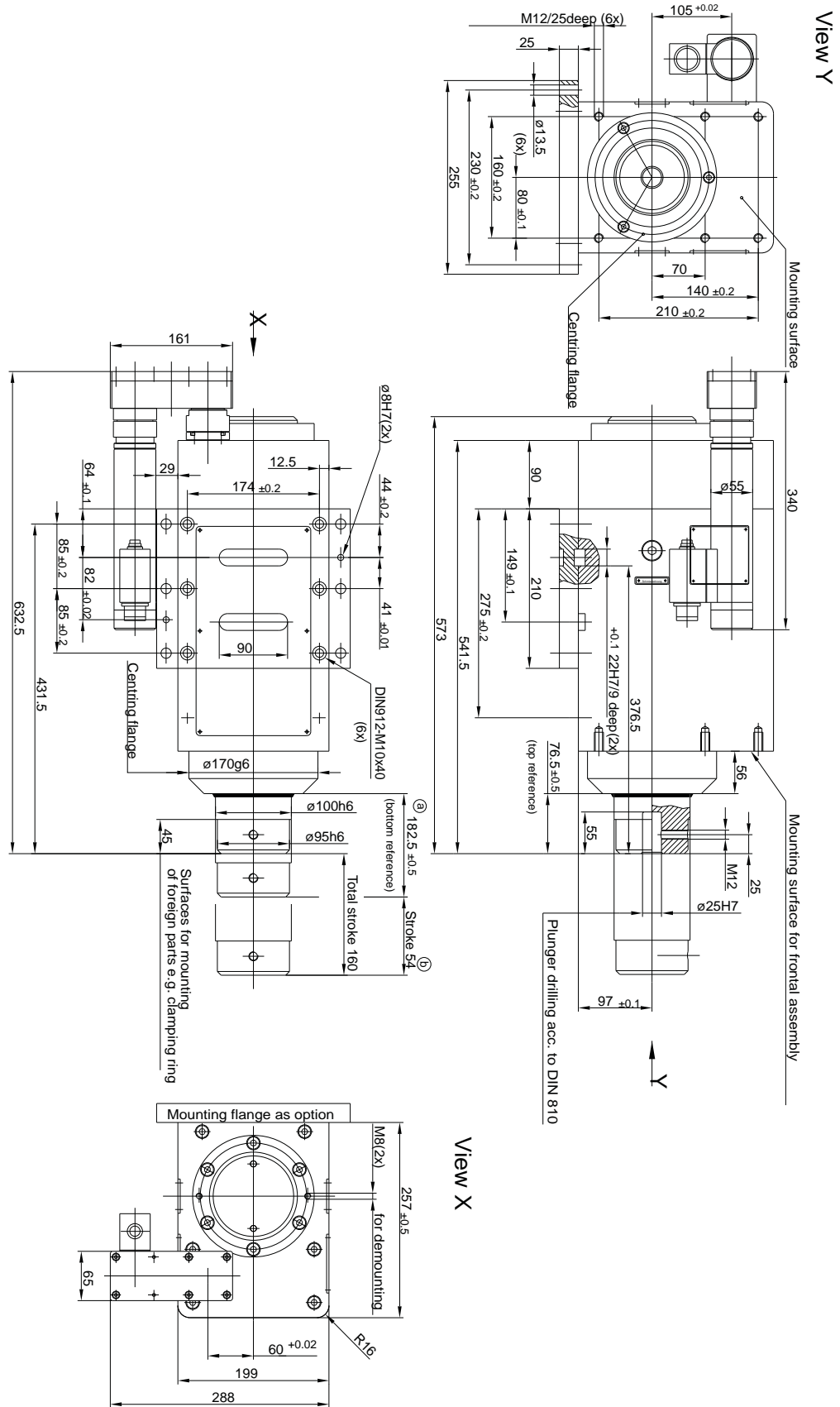

# DIMENSION DRAWING

## EMP 530, EMP 550

Technical modifications reserved!

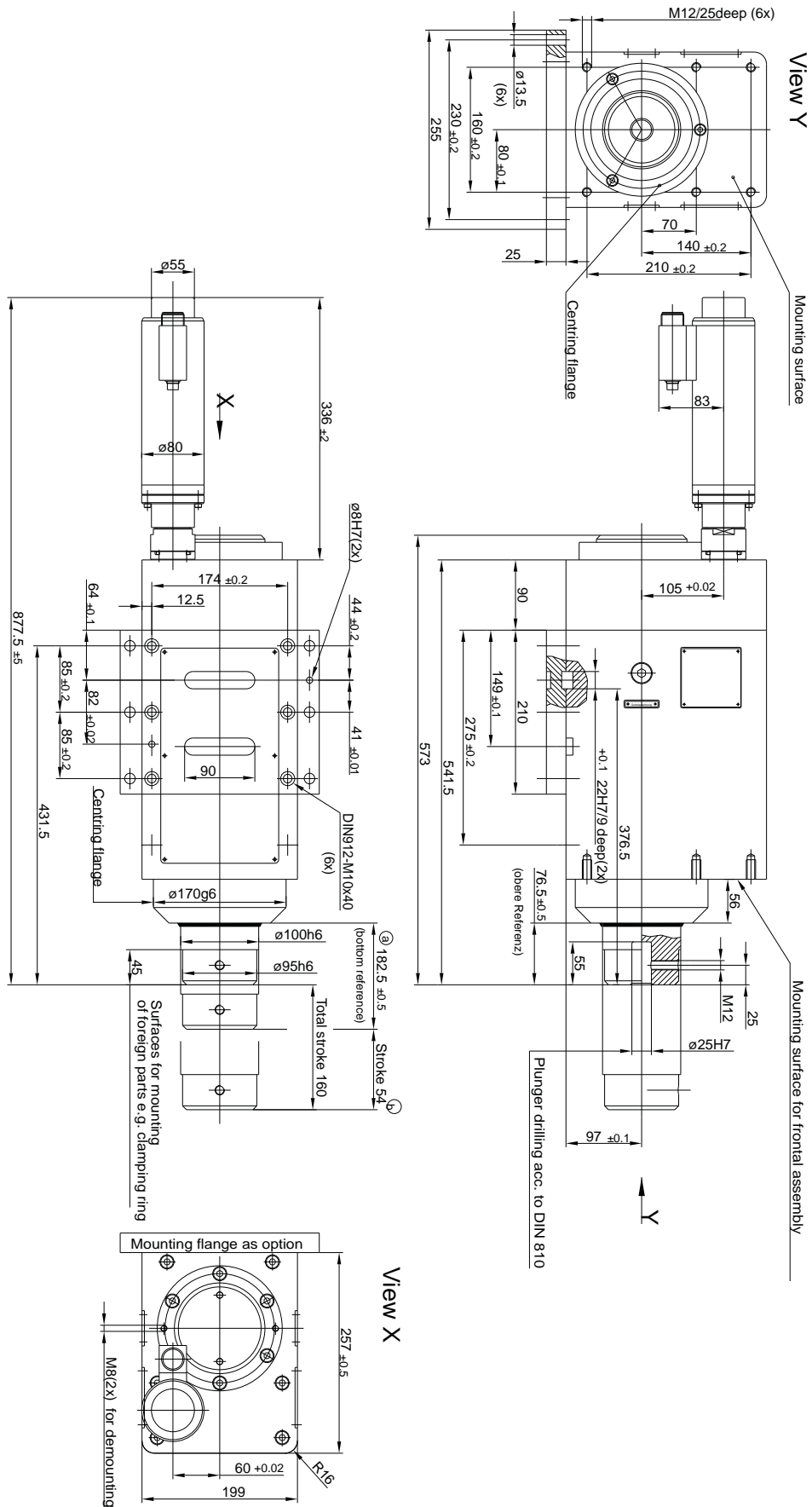

# DIMENSION DRAWING

## EMP 530, EMP 550 with Motor Offset (V2)

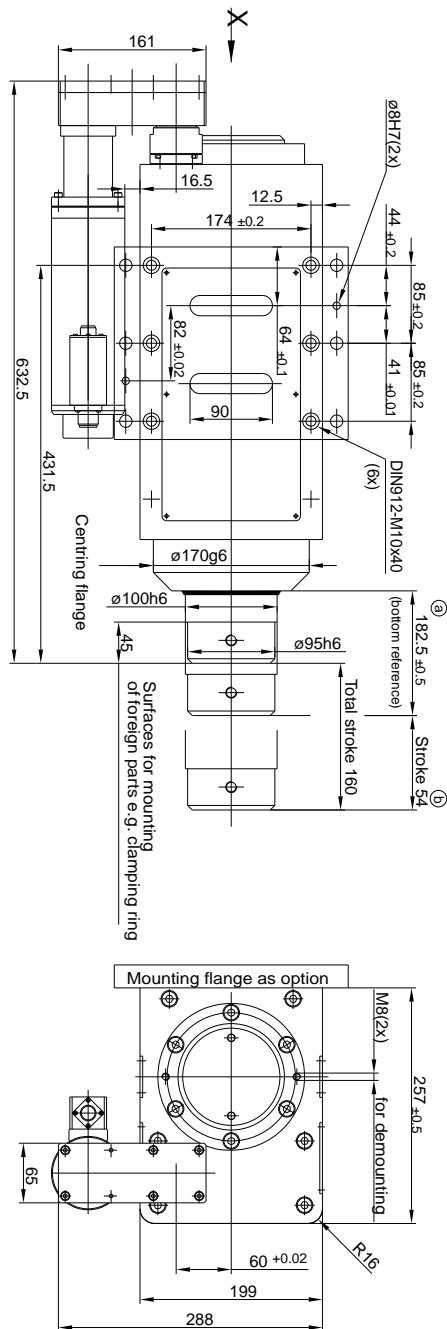
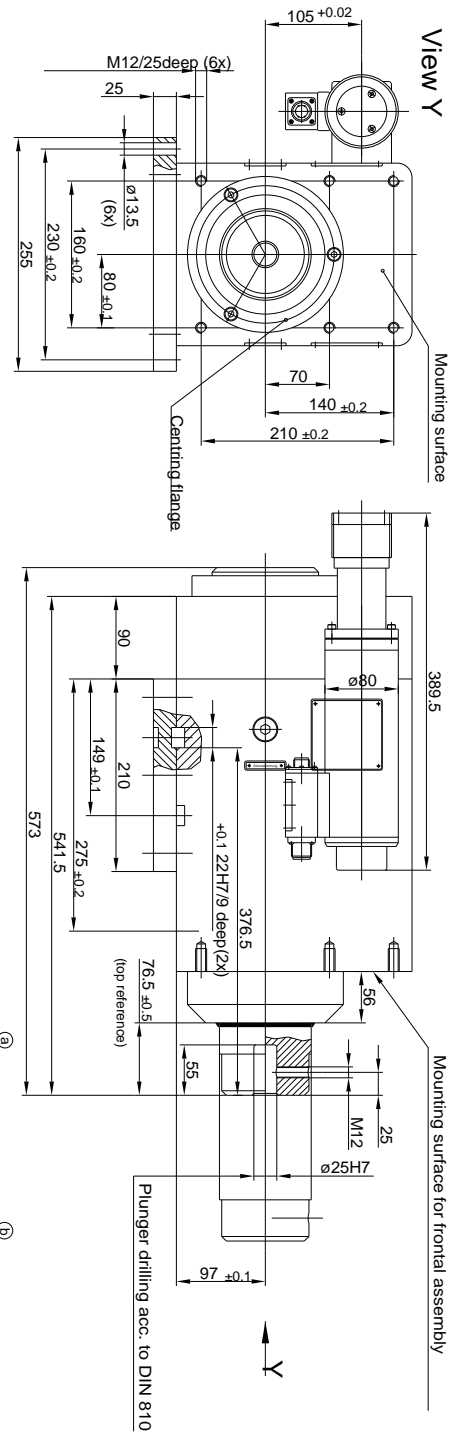

Technical modifications reserved!

# DIMENSION DRAWING

## EMP 530, EMP 550 with 300 mm stroke

Technical modifications reserved!

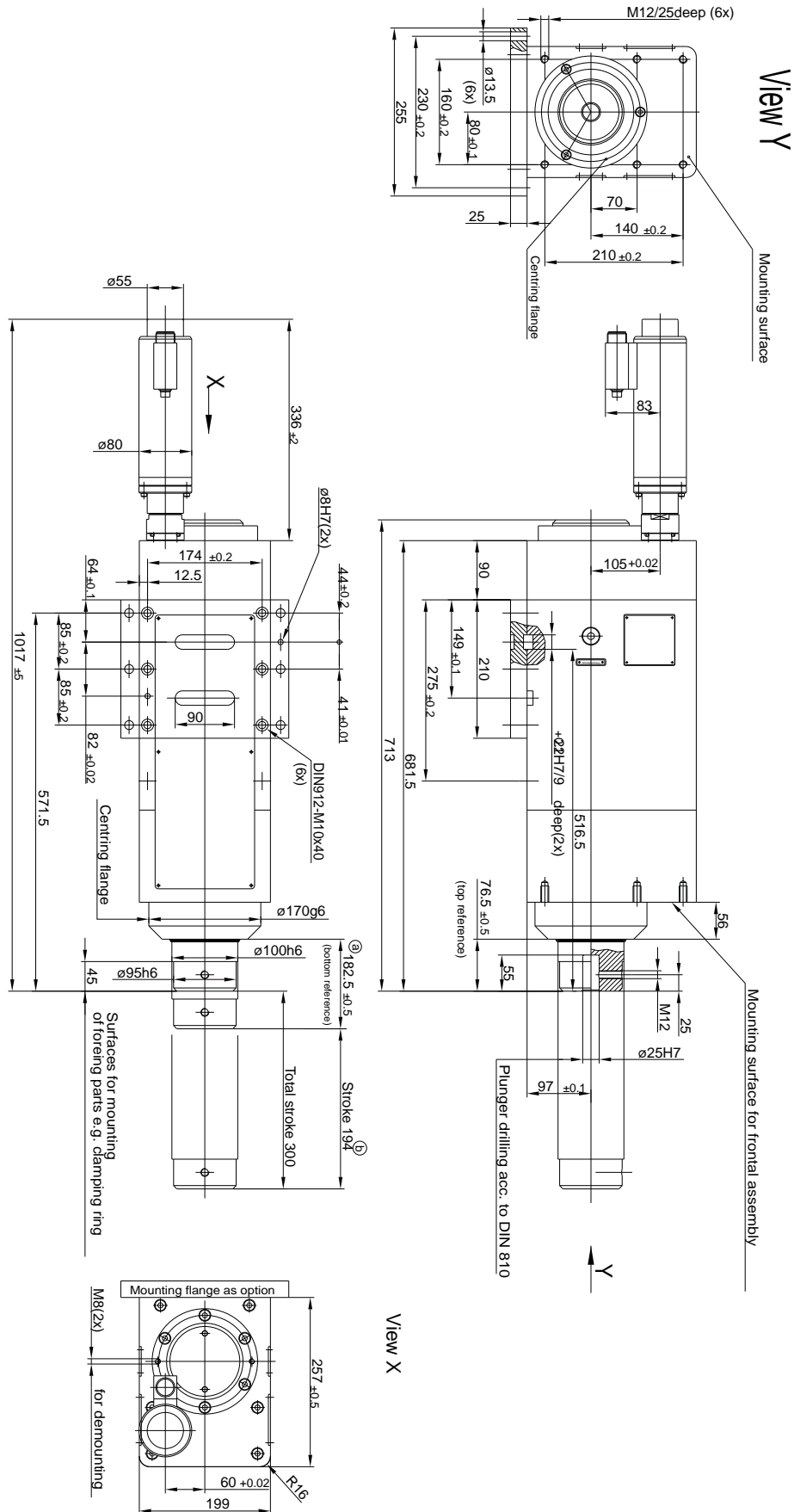

# DIMENSION DRAWING

## EMP 570

Technical modifications reserved!

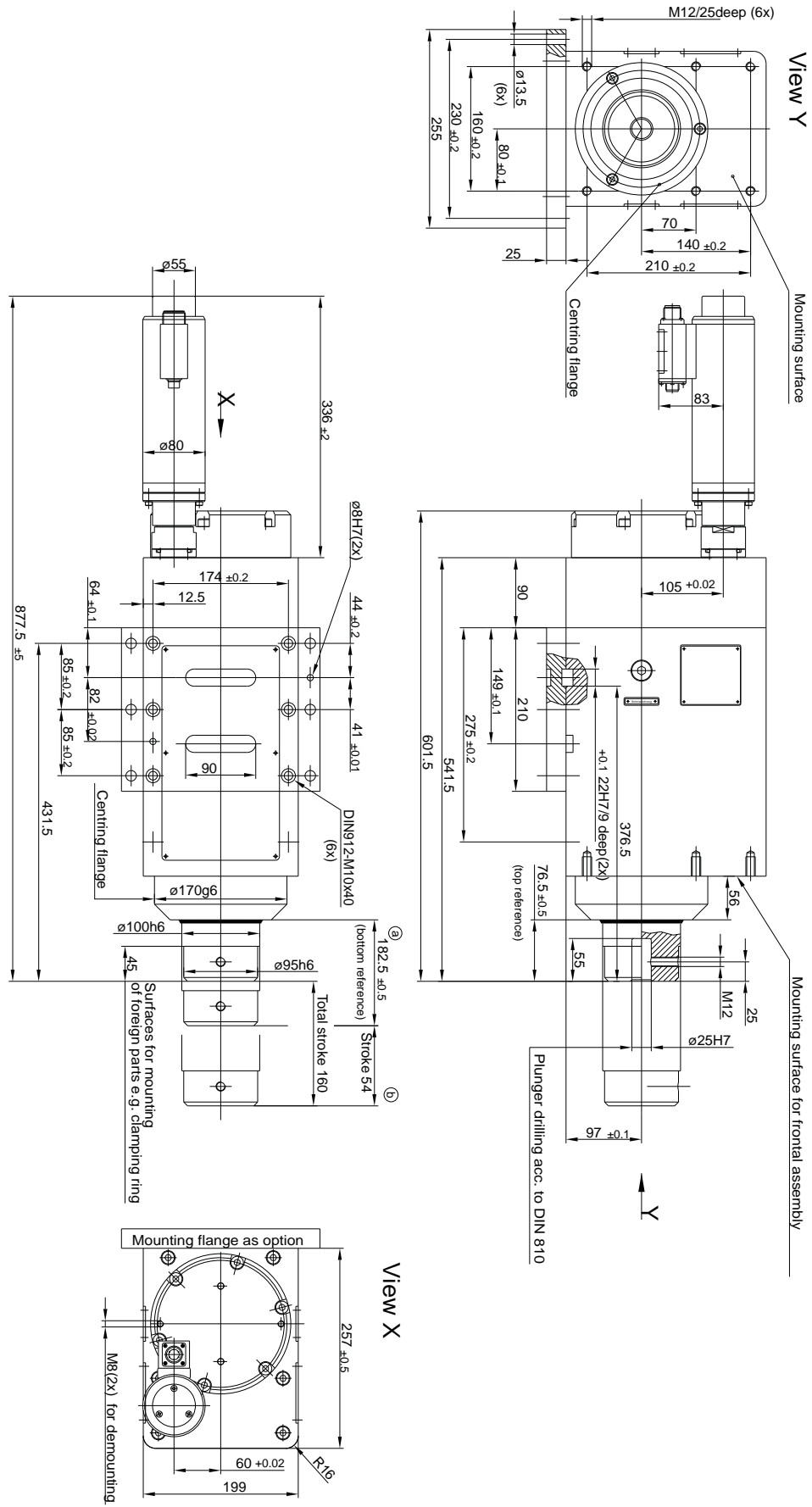

# NOTES

# MECHANICAL INSTALLATION

Dimensions > see page 15 up to 24

## Way of installation 1

The precision press is directly mounted at the back side by using 6 screws.

A fit-in key is used for fixing.

## Way of installation 2

The precision press, equipped with the option mounting plate, is mounted by using 4 screws.

2 cylinder pins are used for fixing.

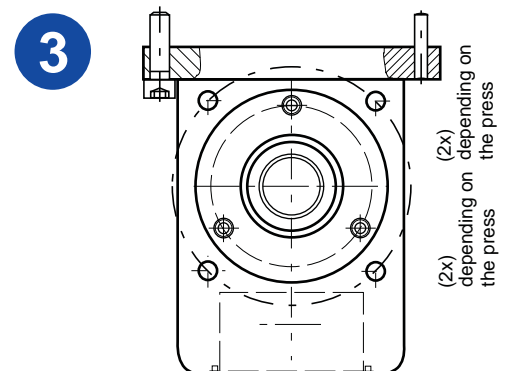
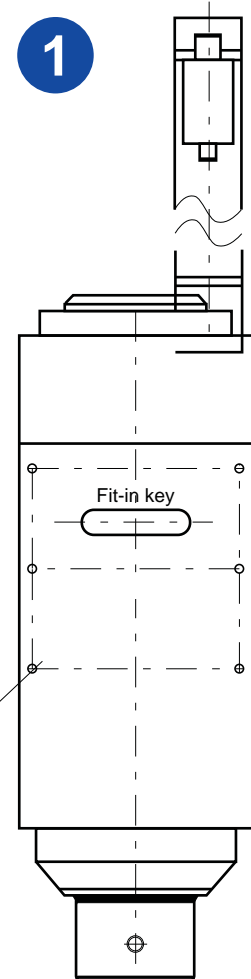
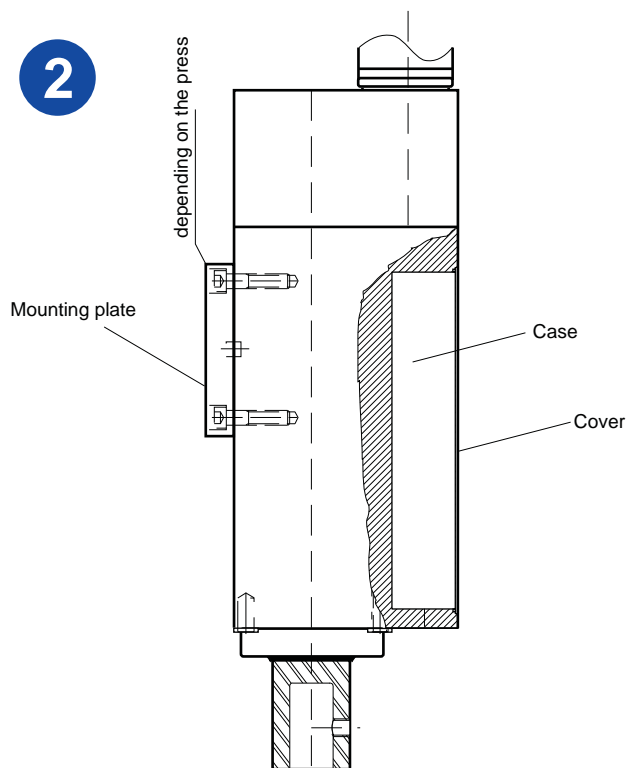

## Way of installation 3

The precision press is directly mounted at the bottom side by using 4 screws.

The guide is used for fixing.

### HINT!

By a horizontal mounting position of the press you have to observe, that the cover of the case shows upwards. If the press is built-in with the cover downwards, you have to observe, that in case of a little over greasing, there's the possibility that grease gets inside the case (measuring and control electronics).

# LUBRICATION DIAGRAM

## Procedure

### I) Recirculating ballscrew

#### Procedure:

1. Drive press to reference 1.
2. Remove screw from lubricating hole ⑦\*.
3. Check, if lubrication hole ⑦\* of the spindle nut corresponds with the case drilling.
4. If so, carry on with step 5.  
If not, the press (spindle nut) manually has to be driven onto position (function 99 of the control unit).
5. Disconnect equipment.
6. Screw in the lubrication pipe into the lubrication hole ⑦\* of the nut (take care of correct fit).
7. Fit the grease gun onto lubrication cup at lubrication pipe and inject grease (Klüberplex BE 31 - 102) acc. to schedule (see below) or equal grease (see data sheet).
8. Remove lubrication pipe and close lubrication hole ⑦\* with screw.

### HINT !

Because the precision press isn't completely maintenance-free, we recommend to grease the press after every 500 000 cycles.

### ATTENTION!

The use of the wrong or too much grease can cause destructions of the unit! It's absolute necessary to carry out step 8 before the press is moved. Otherwise this may also cause destruction of the press!

### II) Helical gear box

#### Procedure:

1. Fit the grease gun onto the lubrication cup \*. This is at the top part of the EMP case.  
Inject grease (Klüberplex BE 31 - 102) acc. to schedule (see below) or equal grease (see data sheet).

#### Schedule 'Quantum and Dosing'

Size 3	Size 4	Sieze 5	
0,5 cm <sup>3</sup>	1 cm <sup>3</sup>	2 cm <sup>3</sup>	Quantum
1/2 stroke*	1 stroke*	2 strokes*	Dosing

\*Specification only valid for DSM lubrication set!

### HINT !

\*) The numbers like e.g. ⑦ are hints for the assembly sketch on page 13!

# DATA SHEET FOR LUBRICANT

## Data sheet lubricant

Characteristic data	Klüberplex BE 31 - 102
Service temperature range,* DIN 51 825 / 51 821/2, °C, approx.	-20 to 120
FAG-FE 9 test, DIN 51 821/ 2, n=6000 min <sup>-1</sup> , <sup>a</sup> F = 1500 N, L <sup>50</sup> - basic rating life, h/°C	160 / 120
Flow pressure, DIN 51 805 1400 mbar, °C, approx.	-20
Colour	beige, brownish
Texture	homogeneous, fibrous
Density, DIN 51 757 at 20 °C, g/cm <sup>3</sup> , approx.	0,86
Base oil viscosity, DIN 51 561 at 40 °C, mm <sup>2</sup> /s, approx. at 100 °C, mm <sup>2</sup> /s, approx.	100 12
Drop point, DIN ISO 2176, °C	> 190
Speed factor (n x dm), mm x min <sup>-1</sup> , approx.	500 000
Worked penetration, DIN ISO 2137, at 25 °C: 0,1 mm	265 - 295
Consistency class, DIN 51 818	2
Corrosion protection (Emcor-Test), DIN 51802, 1 week distilled water, corrosion rating	0/1

*\* Service temperatures are guide values which depend on the lubricant's composition, the intended use and the application method.*

*The upper service temperature of Klüberplex BE31-102 was determined acc. to DIN 51 825 and DIN 51 821 Pt 2, the lower temperature was fixed acc. to DIN 51 825 and DIN 81 805 (flow pressure 1400 mbar).*

# LUBRICATION DIAGRAM

## Accessories

<b>Lubrication Set</b>		<b>art. DSM 280990</b>
1 Pcs.	Grease gun	art. DSM 280985
1 Pcs.	Armoured tube with hydraulic mouthpiece	art. DSM 280987
1 Pcs.	Grease cartridge (400 g)	art. DSM 280981
3 Pcs.	Lubrication pipes	art. DSM 280983
	1 Pcs. Lubrication pipe EMP 3xx size of thread M5	
	1 Pcs. Lubrication pipe EMP 4xx size of thread M6	
	1 Pcs. Lubrication pipe EMP 5xx size of thread M8	



# FUNCTION DESCRIPTION

## Measuring and control electronics

### The purpose of the functional part 'measuring and control electronics' is:

- the protection of mechanical damages (BRUSI = break fuse)
- limiting of the operating range (SWO - SWU)
- the drive to the reference points (REF1 and REF2).

**ATTENTION!** Failure to observe the following hints can cause damages at the precision press.  
Therefore take care of a professional connection of the press and their components.

The measuring and control electronics demands the connection to a DSM control unit. An external PLC for monitoring and control of the press isn't necessary, but can be connected at any time via the resource interface (BMS).

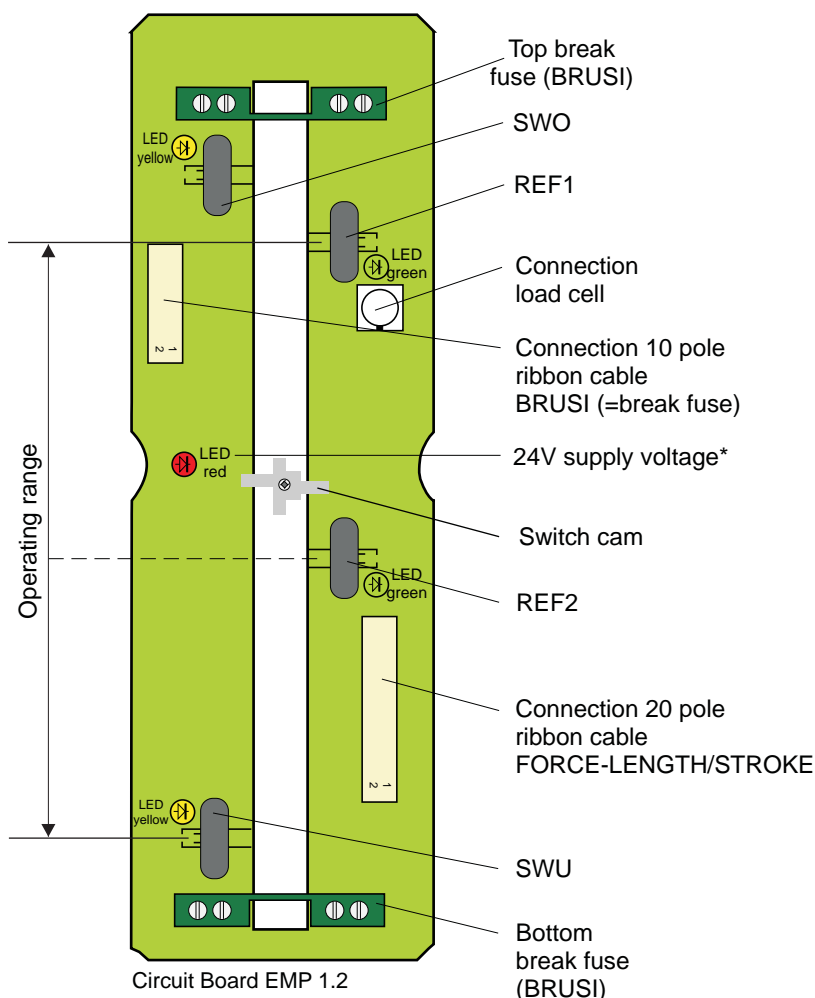

\* A shiny LED shows, that the 24V supply voltage is set.

The measuring and control electronics is equipped with 4 hall sensors and 2 break fuses to monitor the final positions as well as the reference points of the operating range of the press spindle. The basic position of the press is always activated, if the hall sensor 'Reference Point' (REF1 or REF2) is achieved from the top. So that not the complete operating range has to be covered because of the zero adjustment, it selectively has to be run to two reference points (REF1 and REF2). This kind of zero adjustment (REF1 or REF2) enables a much shorter cycle time as it was up to now. From the top it constantly has to be run to the reference point to completely compensate the reversal backlash. To arise the switching accuracy, it's furthermore recommended, to drive in the reference point with a low speed (e.g. 5 mm/s). The software fuse at the top (SWO) is only used inside of the unit or in manual mode.

# BREAK FUSE

## Measuring and control electronics

If the specified guideway of the press is exceeded for any reason, the break fuses 'BRUSI' at the top respectively 'BRUSI' at the bottom are destroyed (ill. A).

The destroyed break fuse has to be exchanged against an original DSM break fuse (art. DSM 280611). Find out the reason for the crossing of the software fuse (SWO).

**Remove the cause of defect before you run the press again respectively insert the new 'BRUSI'.**

To run the press into the specified operating range again, the new 'BRUSI' is built-in mirror-inverted (ill. B).

Now the press can be run into the specified operating range by manual operation.

After that, the new inserted 'BRUSI' has to be set into the correct position (ill. C).

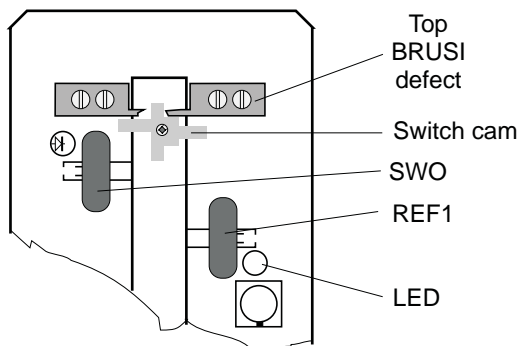

*Break fuse destroyed.  
Switch cam has crossed SWO  
as well as the top BRUSI.*

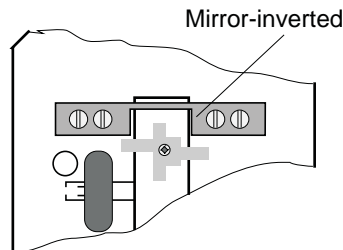

*New break fuse is built-in  
mirror-inverted.  
After the defect is removed, the  
switch cam can be driven into  
the operating range manual.*

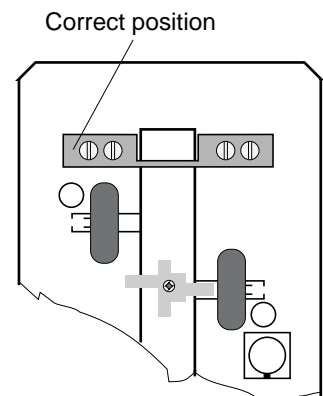

*Break fuse is turned and  
by that set into the correct  
position.*

There are 4 LEDs on the circuit board EMP 1.2 (measuring and control electronics) for control of the 4 hallsensors. By drive to the hallsensors, the corresponding LED lights up.

Modifications respectively foreign changes on the circuit board EMP 1.2 outside of the manufacturers company (DSM, Aalen) are not allowed.

# ELECTRICAL INSTALLATION

## Complete System

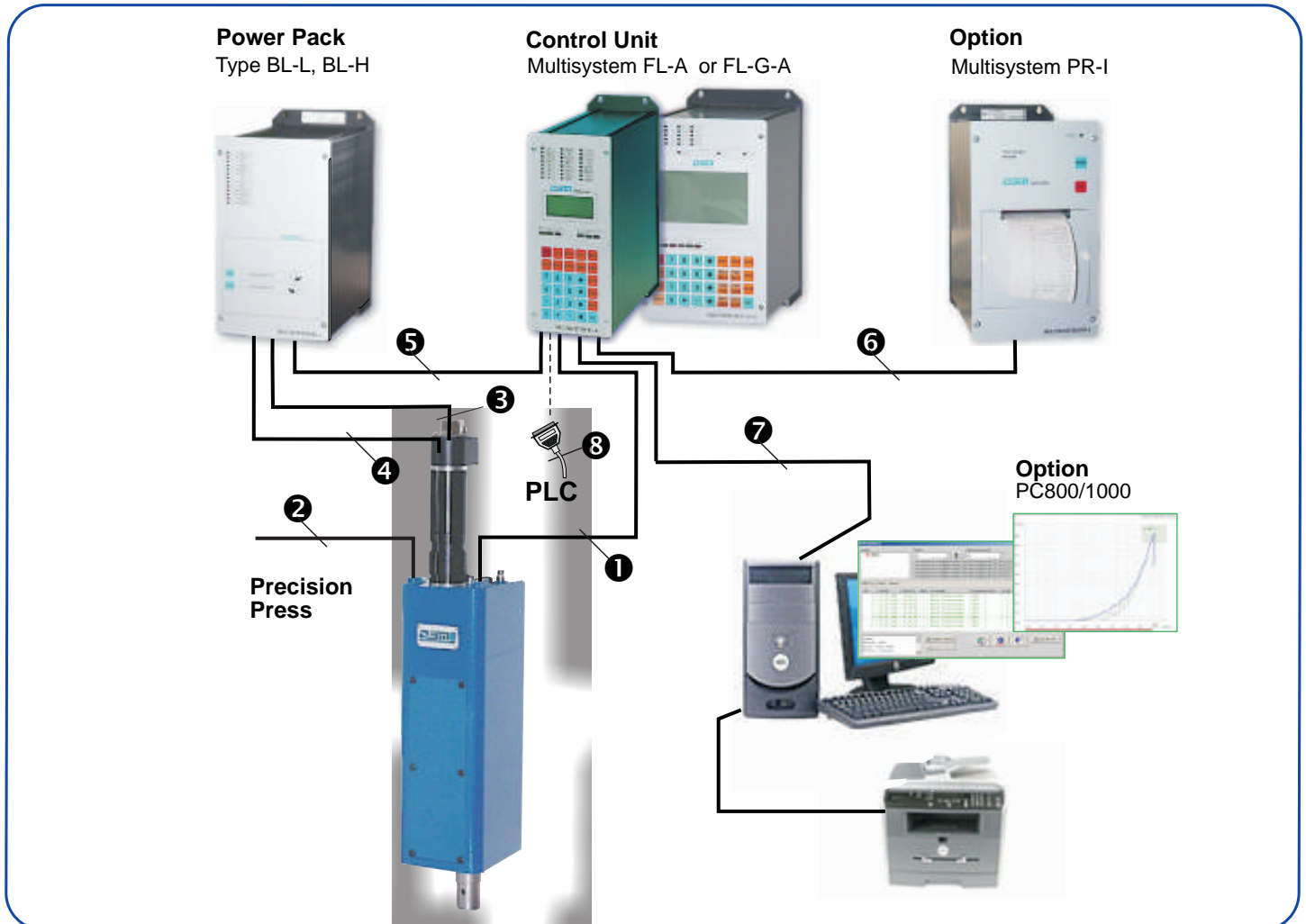

No.	Description		Length	Comment	art.
①	EMP force-length/stroke cable	X80	5 m 10 m 15 m		DSM 280508 DSM 280509 DSM 280510
②	BRUSI plug	X81	—	Cable provided by customer, 9 pole plug	DSM 280511
③	Motor cable	X22	5,10,15	from EMP 301 - 410 from EMP 520 - 570	DSM 280512 DSM 280513
④	EMP hallsensor cable	X23	5 m 10 m 15 m		DSM 280602 DSM 280603 DSM 280604
⑤	LT cable	X5	0,8		DSM 280515
⑥	Printer cable	X7	2		DSM 280516
⑦	PC cable	X6	2		DSM 921988
⑧	BMS connection	X52	Plug	Cable provided by customer, 25 pole plug	DSM 280524

# CONFIGURATIONS

## X80, X81, X82

### X81 BRUSI 9 pole MIN-D plug

PIN	CONFIGURATION	
1	Break fuse 0V	Output
2	nc	
3	0V	Input
4	BM	Option brake
5	BP	Option brake
6	Break fuse 24V	Output
7	+ 24V	Input
8	BM	Option brake
9	BP	Option brake

**ATTENTION!** 24V have to be supplied to the interface X81 BRUSI (see above) by the customer before the putting into operation. These 24V are as supply voltage for the monitoring electronics, which is inside the press.  
These 24 V are guided over the break fuses, which are built-in in the press and are available for customers monitoring at the PINs 1 and 6 of the interface X81 BRUSI. This for example may be made by a PLC.

**The reverse voltage (24 V from BRUSI) has to be controlled by the customer!  
It's not possible to run the press without a 24 V supply!**

### X80 FORCE / LENGTH (STROKE) 15 pole MIN-D plug

PIN	CONFIGURATION
1	Calibrate
2	I-output
3	+ 12V
4	SC
5	nc
6	Length (stroke) 1
7	Top limit switch EU
8	GND
9	Limit switch reference RF
10	nc
11	Top limit switch EO
12	GND
13	+ 5V
14	Length (stroke) 2
15	DI

### X82 TRIGGER BNC

for connection to a counter measurement device

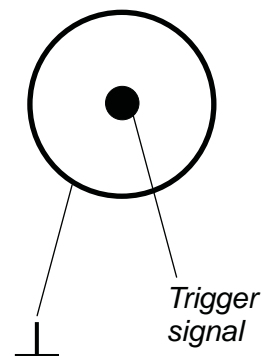

## HINT!

The configurations which additional are needed you can get from the corresponding manuals (Multisystem FL-A, Multisystem FL-G-A, Power Pack) !

# Switch-Off Example

## Disconnection motor precision press for sizes 3xx and 4xx

### Example:

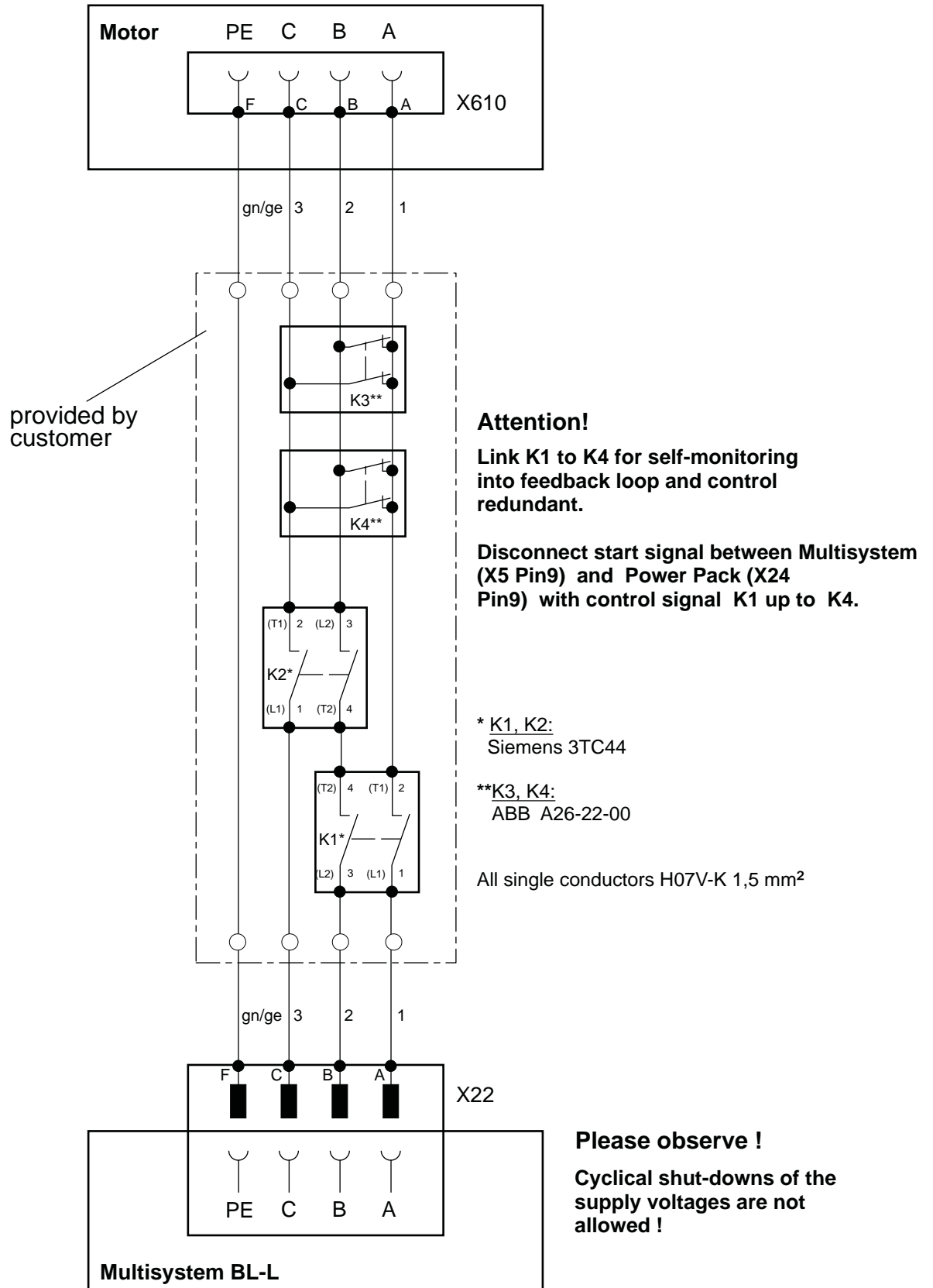

# SWITCH-OFF EXAMPLE

## Disconnection motor precision press for size 5xx

### Example:

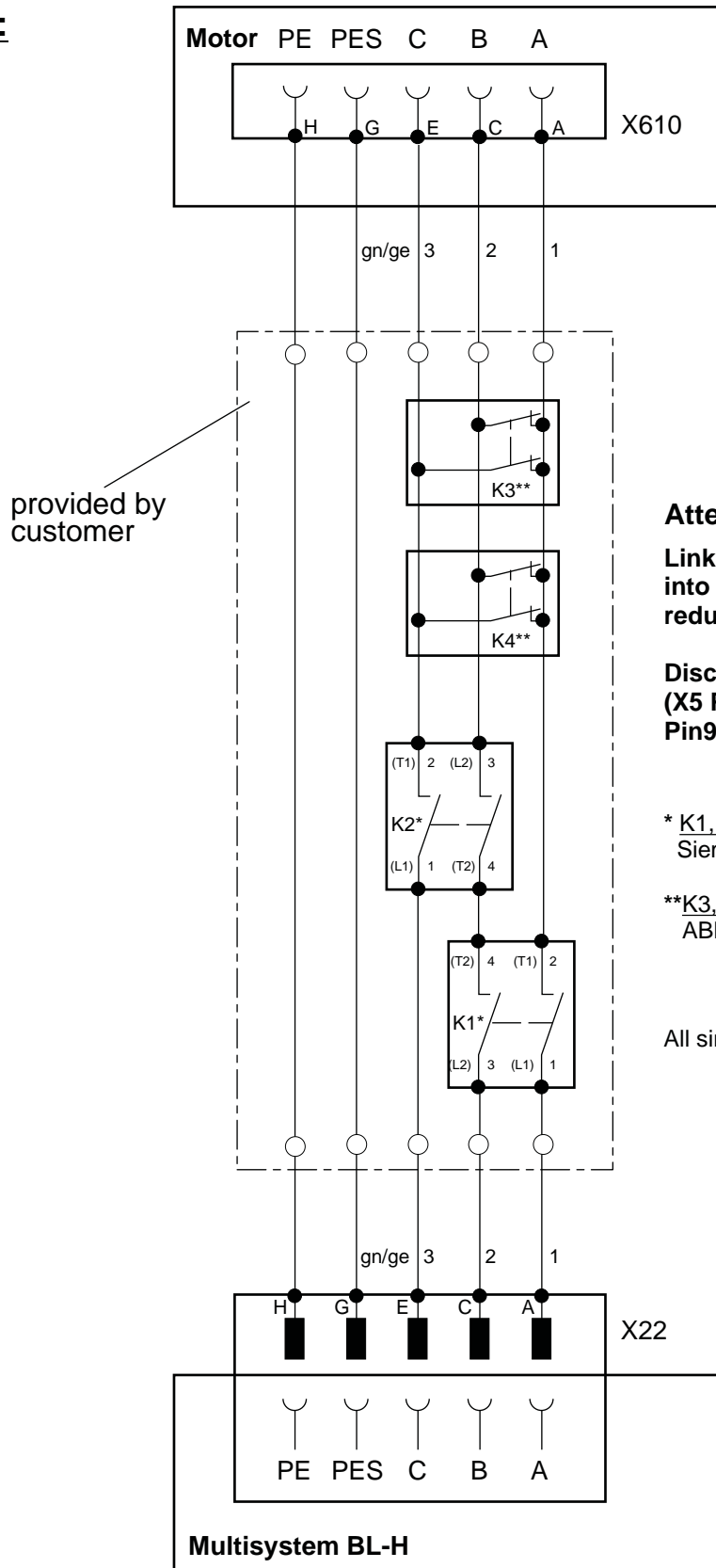

### Attention!

Link K1 to K4 for self-monitoring into feedback loop and control redundant

Disconnect start signal between Multisystem (X5 Pin9) and Power Pack (X24 Pin9) with control signal K1 to K4.

\* K1, K2:  
Siemens 3TC44

\*\*K3, K4:  
ABB A26-22-00

All single conductors H07V-K 1,5 mm<sup>2</sup>

**Please observe !**  
Cyclical shut-downs of the supply voltages are not allowed!

# DSM CERTIFICATE

In case of a return delivery of the press, please enclose a copy of this page. This certificate is also the letter of guarantee.

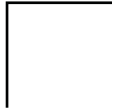

Customer: \_\_\_\_\_

## CONTACT / LOCATION PLAN

### Address



DSM Messtechnik GmbH  
Dieselstraße 16  
73431 Aalen  
Germany

### P.O. Box



DSM Messtechnik GmbH  
P.O. Box 12 01  
73430 Aalen  
Germany

### Internet



[www.dsm-messtechnik.de](http://www.dsm-messtechnik.de)

### How to find us:



### Section 'Industriegebiet West'

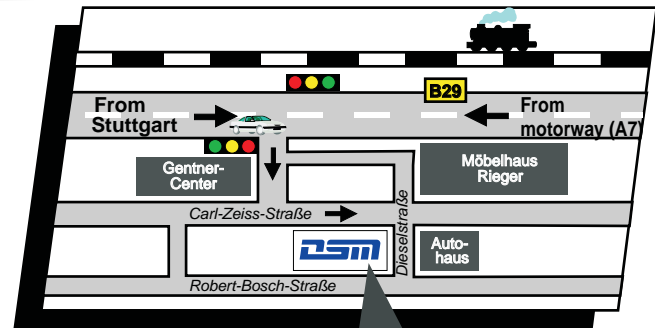

DSM Messtechnik GmbH

### Contact Persons Sales

**Mr. Florian Wilhelm** (Product Manager)

Telephone: +49 (0) 7361 / 5717 - 43  
Telefax: +49 (0) 7361 / 5717 - 33  
E-Mail: [fwilhelm@dsm-messtechnik.de](mailto:fwilhelm@dsm-messtechnik.de)

**Mr. Michael Moll** (Documentation, Sales)

Telephone: +49 (0) 7361 / 5717 - 44  
Telefax: +49 (0) 7361 / 5717 - 33  
E-Mail: [moll@dsm-messtechnik.de](mailto:moll@dsm-messtechnik.de)

**Mr. Marc Bartjen** (Sales)

Telephone: +49 (0) 7361 / 5717 - 45  
Telefax: +49 (0) 7361 / 5717 - 33  
E-Mail: [bartjen@dsm-messtechnik.de](mailto:bartjen@dsm-messtechnik.de)

### Contact Persons Service

**Mr. Salvatore Miggiano** (Service Manager)

Telephone: +49 (0) 7361 / 5717 - 27  
Telefax: +49 (0) 7361 / 5717 - 33  
E-Mail: [miggiano@dsm-messtechnik.de](mailto:miggiano@dsm-messtechnik.de)

**Mr. Thomas Schips** (Service, Quality Assurance)

Telephone: +49 (0) 7361 / 5717 - 28  
Telefax: +49 (0) 7361 / 5717 - 53  
E-Mail: [schips@dsm-messtechnik.de](mailto:schips@dsm-messtechnik.de)

# DSM SERVICE FORM

**If you should send in a precision press EMP, we beg you, to please fill out and enclose the following report.**

*Hint: The return delivery to DSM is on costs and risk of the customer. Also claims and warranty deeds. In case of warranty claims, DSM Messtechnik GmbH takes over the costs for the return delivery to the customer.*

## Unit specification

Type description

Serial number

Please take the type description of the press as well as the corresponding serial number from the type plate.

## Contact person(s) for technical questions:

Company:

Department:

Ms. / Mrs. / Mr.:

Telephone:

Street, Post Code, Place:

### Wished handling

- Check of press, cost estimate
- Repair
- Calibration \*)
- Rebuilding / Modification \*)

\*) Customer PO #

### Appearance of the error

- from the beginning
- after the unit worked faultless
- .....
- .....
- .....

### Settings, Configurations

.....

.....

### Problem Description

.....

.....

.....

.....

.....

.....

**EG DECLARATION OF CONFORMITY**We, **DSM Messtechnik GmbH**Address **Dieselstraße 16  
D-73431 Aalen  
Germany**

hereby certify in only responsibility, that the component

**Precision Press****EMP 301 / 302 EMP 403 / 405 / 410  
EMP 510 / 520 / 525 / 530 / 550 / 570**

to which this declaration refers, corresponds in its standard execution to the following standards and/or normative documents:

**Harmonized EG Directives****Machinery Directive 98/37/EG**DIN EN 292 Part 1 and 2 Reliability of machines  
DIN EN 954 Part 1 Reliability of machines  
DIN EN 1050 Reliability of machines**Low Voltage Directive 73/23/EWG**IEC 60364 (VDE 0100) Set up of low voltage plants  
EN 60204 Part 1 (VDE0113) Electrical equipment of machines  
DIN VDE 0110 Part 2 Insulation coordination for electrical manufacturing resources in low voltage plants**Testing of the VDE safety measures conform with the following standards (individual testing)**EN 60364-6-61 Set up of low voltage plants-certificates/  
(VDE 0100 Part 610) first certificates  
DIN VDE 0805 Reliability of devices of the communication technology  
DIN VDE 0105 Operation of electrical devicesDIN VDE 0700 Part 1  
DIN VDE 0701  
DIN VDE 0740 Part 1Reliability of electrical units  
Modification and testing of electrical units  
Reliability of hand-operated power tools  
(right angle nutrunner BLH51, DS26)**EMVG****All units are conform with the following standards (type testing)**EN 61000-4-1 EMV testing and measuring method survey interference resistance testing method  
EN 61000-4-2 EMV testing and measuring method testing of the interference resistance contrary to ESD  
EN 61000-4-4 EMV testing and measuring method testing of the interference resistance contrary to burst  
EN 61000-4-5 EMV testing and measuring method testing of the interference resistance contrary to surge  
EN 61000-4-7 EMV testing and measuring method general guide for the measurement of overtones and 'Zwischenharmonischen'  
EN 61000-3-2 EMV limit values for harmonics currents input current <16 A  
EN 61000-3-3 EMV limit values for voltage fluctuations and flicker input current <16 A  
EN 61000-6-1 EMV generic standard interference resistance small firms  
EN 61000-6-2 EMV generic standard interference resistance industrial sektor  
EN 61000-6-3 EMV generic standard emitted interference small firms  
EN 61000-6-4 EMV generic standard emitted interference industrial sektor

A EMV confirm set-up as well as the wiring has to be observed for the retention of the EMV regulations.

The technical documentation for the above mentioned product is hold by:

**DSM Messtechnik GmbH  
Dieselstraße 16  
D-73431 Aalen  
Germany**

Aalen, 06.04.2005

Place, Date

Raimund Wilhelm, Managing Director  
Name and Signature

Company Stamp

**EG MANUFACTURERS DECLARATION**We, **DSM Messtechnik GmbH**Address **Dieselstraße 16  
D-73431 Aalen  
Germany**

hereby declare, that the component

**Precision Press****EMP 301 / 302 EMP 403 / 405 / 410  
EMP 510 / 520 / 525 / 530 / 550 / 570**

is for the installation into a complete plant respectively for the assembly to a machine and corresponds in its standard execution to the following standards and/or other normative documents::

**Harmonized EG Directives****Machinery Directive 98/37/EG**DIN EN 292 Part 1 and 2 Reliability of machines  
DIN EN 954 Part 1 Reliability of machines  
DIN EN 1050 Reliability of machines**Low Voltage Directive 73/23/EWG**IEC 60364 (VDE 0100) Set up of low voltage plants  
EN 60204 Part 1 (VDE0113) Electrical equipment of machines  
DIN VDE 0110 Part 2 Insulation coordination for electrical manufacturing resources in low voltage plants**Testing of the VDE safety measures conform with the following standards (individual testing)**EN 60364-6-61 Set up of low voltage plants-certificates/  
(VDE 0100 Part 610) first certificates  
DIN VDE 0805 Reliability of devices of the communication technology  
DIN VDE 0105 Operation of electrical devicesDIN VDE 0700 Part 1  
DIN VDE 0701  
DIN VDE 0740 Part 1Reliability of electrical units  
Modification and testing of electrical units  
Reliability of hand-operated power tools  
(right angle nutrunner BLH51, DS26)**EMVG****All units are conform with the following standards (type testing)**EN 61000-4-1 EMV testing and measuring method survey interference resistance testing method  
EN 61000-4-2 EMV testing and measuring method testing of the interference resistance contrary to ESD  
EN 61000-4-4 EMV testing and measuring method testing of the interference resistance contrary to burst  
EN 61000-4-5 EMV testing and measuring method testing of the interference resistance contrary to surge  
EN 61000-4-7 EMV testing and measuring method general guide for the measurement of overtones and 'Zwischenharmonischen'  
EN 61000-3-2 EMV limit values for harmonics currents input current <16 A  
EN 61000-3-3 EMV limit values for voltage fluctuations and flicker input current <16 A  
EN 61000-6-1 EMV generic standard interference resistance small firms  
EN 61000-6-2 EMV generic standard interference resistance industrial sektor  
EN 61000-6-3 EMV generic standard emitted interference small firms  
EN 61000-6-4 EMV generic standard emitted interference industrial sektor

A EMV confirm set-up as well as the wiring has to be observed for the retention of the EMV regulations.

The putting into operation is so long forbidden, until it's made sure, that the complete machine, in which DSM products are being build in, corresponds to the regulations of the EGDirective 98/37/EG.

The technical documentation for the above mentioned product is hold by:

**DSM Messtechnik GmbH  
Dieselstraße 16  
D-73431 Aalen / Germany**

Aalen, 06.04.2005

Place, Date

Raimund Wilhelm, Managing Director  
Name and Signature

Company Stamp

**\*Note: The CE-sign am at the unit runs out of validity as soon as the component is used in a complete plant.**

# DSM Product Range

DSM Messtechnik GmbH

- your professional and innovative partner in the divisions fastening technique, press-in technique, assembly technique, test technology and automation.

All from one source!

From the components to the system:

Precision fastening and automotive tools, precision presses, monitoring and control units, handling systems, complete fastening, press-in and assembling systems, quality assurance as well as customer-specific single work stations.



Success through Quality  
... for that we stand since 25 years

DSM Messtechnik GmbH  
Dieselstraße 16 D-73431 Aalen

Phone +49 (0) 7361 / 5717 - 0  
Telefax +49 (0) 7361 / 5717 - 33

E-Mail [info@dsm-messtechnik.de](mailto:info@dsm-messtechnik.de)  
Internet [www.dsm-messtechnik.de](http://www.dsm-messtechnik.de)

[Schraubtechnik] [Press- / Fügetechnik] [Montagetechnik] [Prüftechnik] [Automation]  
[Fastening Technique] [Press-In Technique] [Assembly Technique] [Test Technology] [Automation]